



Targetry Plans and Status

MUTAC Review

FNAL

March 17, 2006



International Scoping Study

Question: Given a “Green Field” what are the most favorable parameters for a proton driver to a Neutrino Factory?

A related question: Liquid or Solid Target

Can a solid target survive a $>1\text{MW}$ proton driver beam?

(Nick Simos → Solid Target Studies)

Is a liquid target for a $>1\text{MW}$ proton driver technically feasible?

(MERIT target experiment at CERN)

What is the “preferred” proton driver energy?

Achieving Intense Muon Beams

Maximize Pion/Muon Production

- Soft-pion Production
- High Z materials
- High Magnetic Field

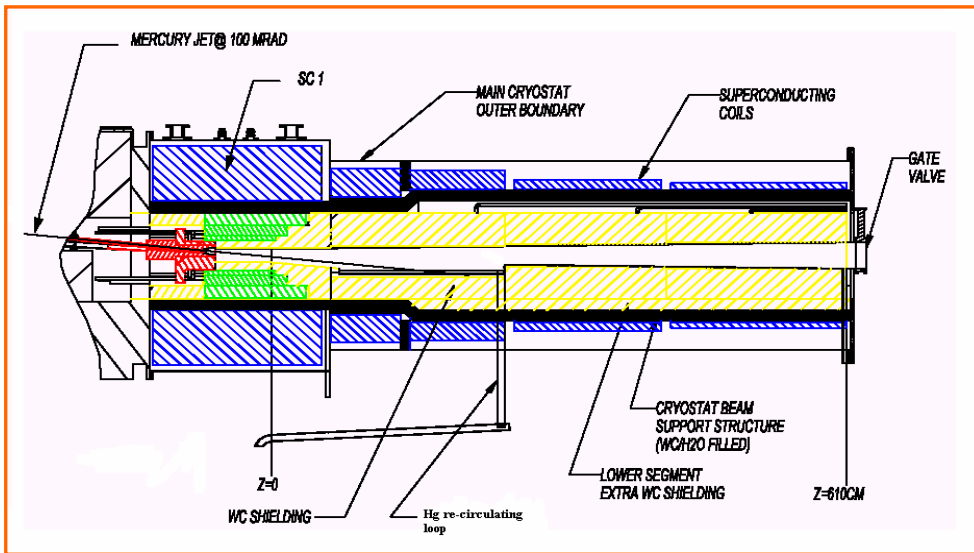

Meson Production - 16 GeV $p + W$

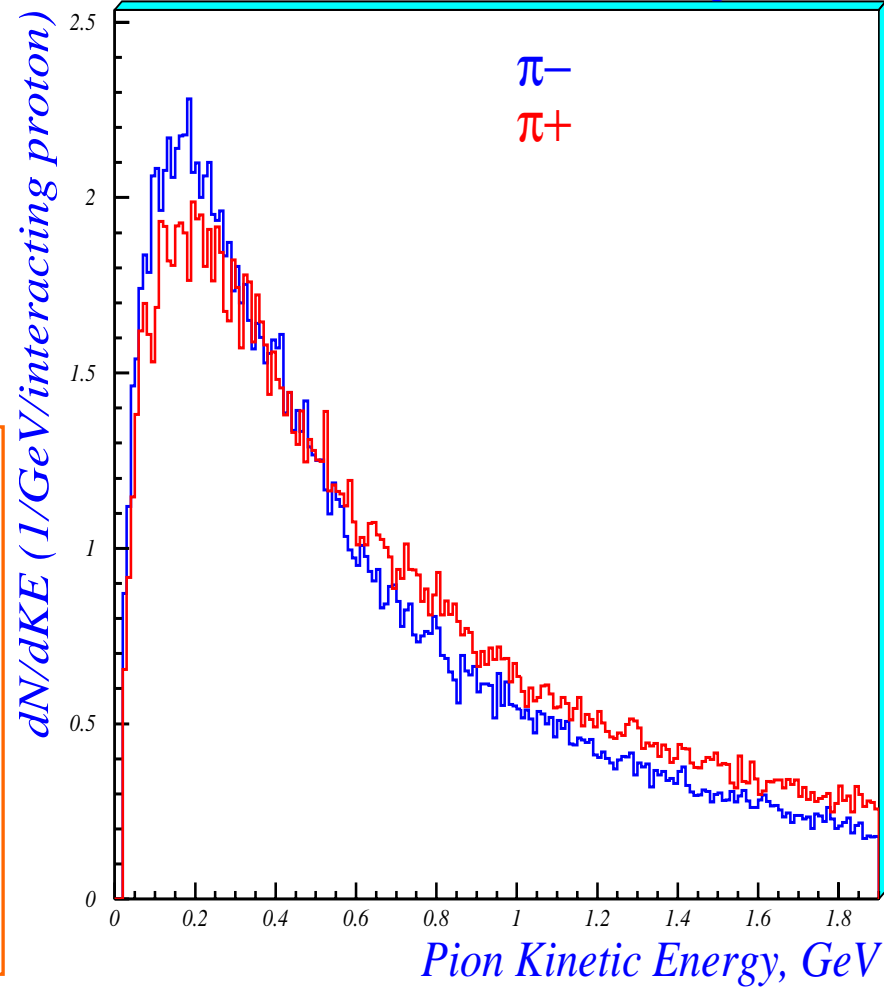

Optimizing Soft-pion Production

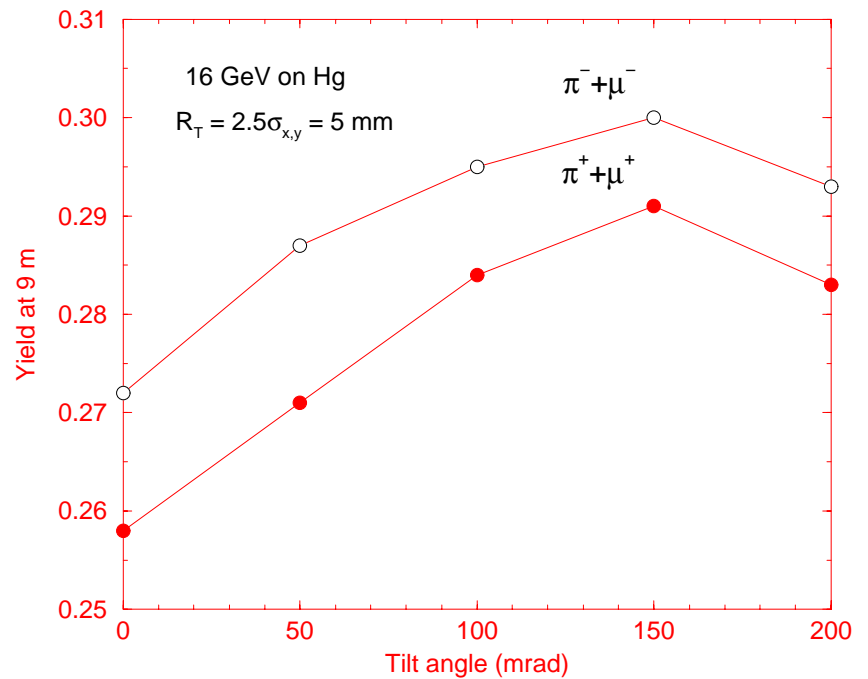
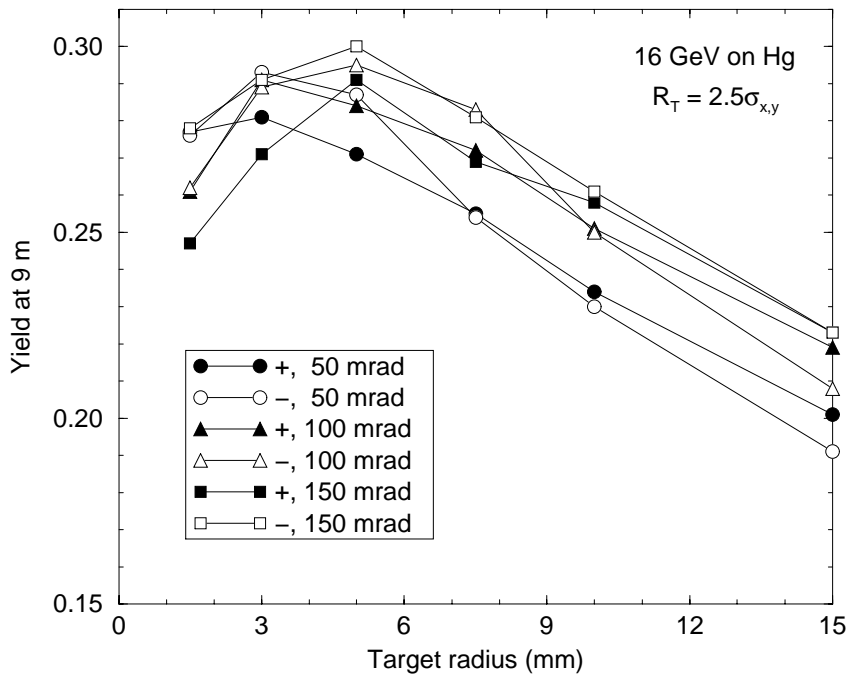

Process mesons through Cooling

Consider mesons within acceptance of $\epsilon_{\perp} = 30\pi$ mm and $\epsilon_L = 150\pi$ mm after cooling

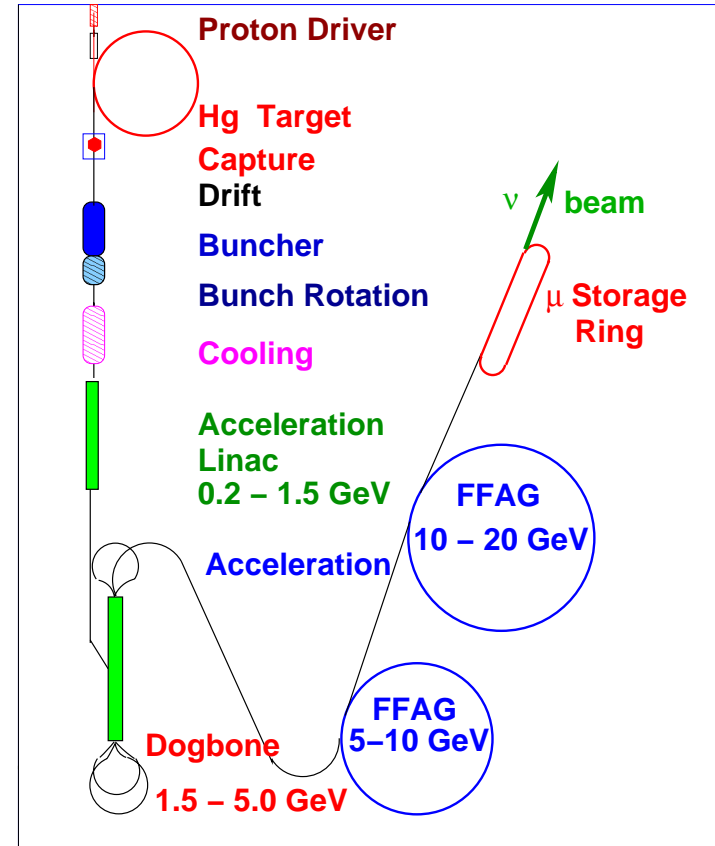
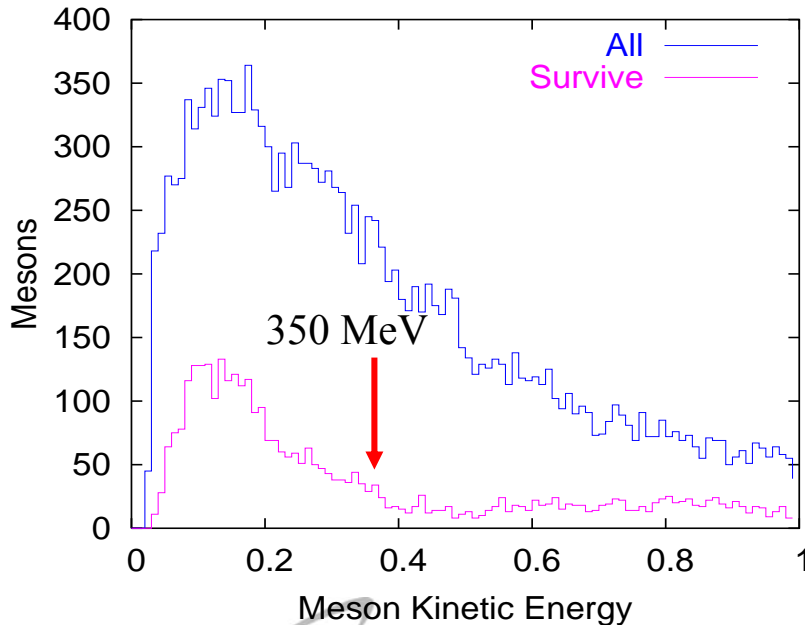

Use meson count with **KE < 350 MeV** as a figure of merit.

Meson KE < 350 MeV at 50m

MARS14

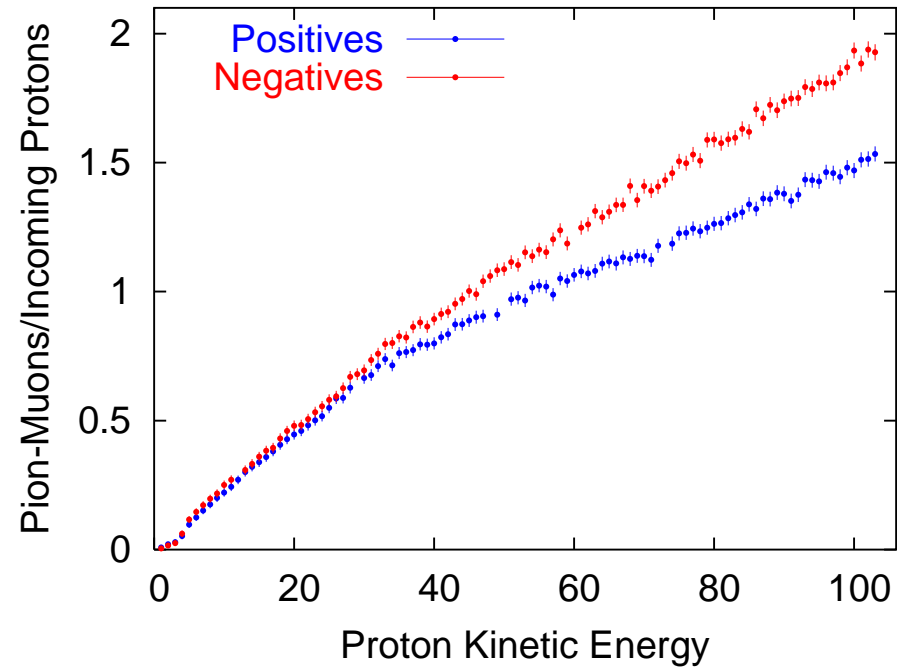

Mesons/Proton

MARS14

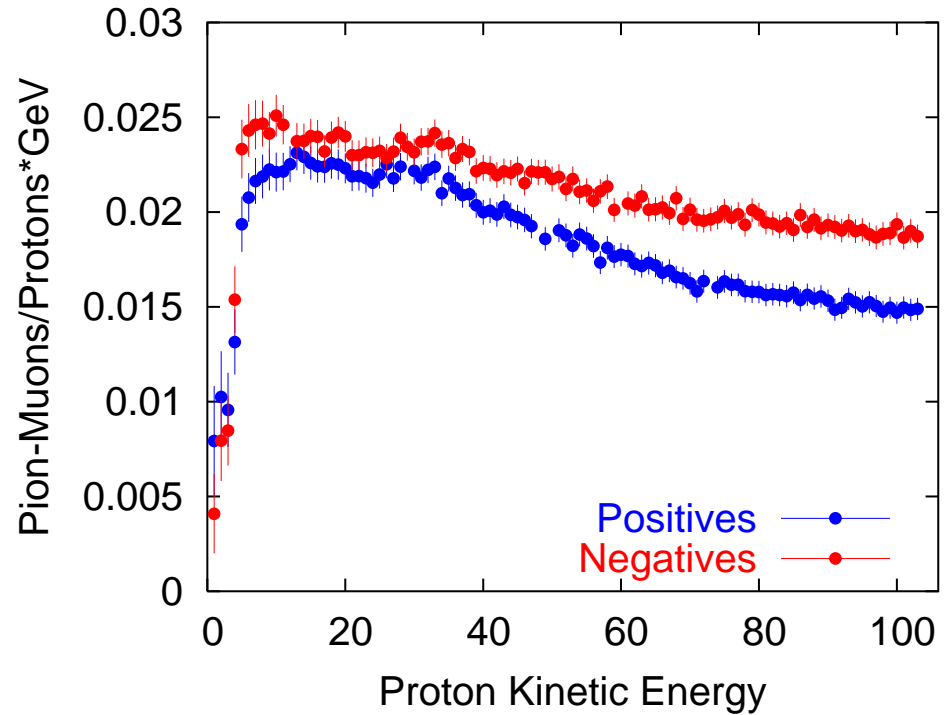

Mesons/Proton normalized to beam power

Post-cooling 30π Acceptance

MARS14

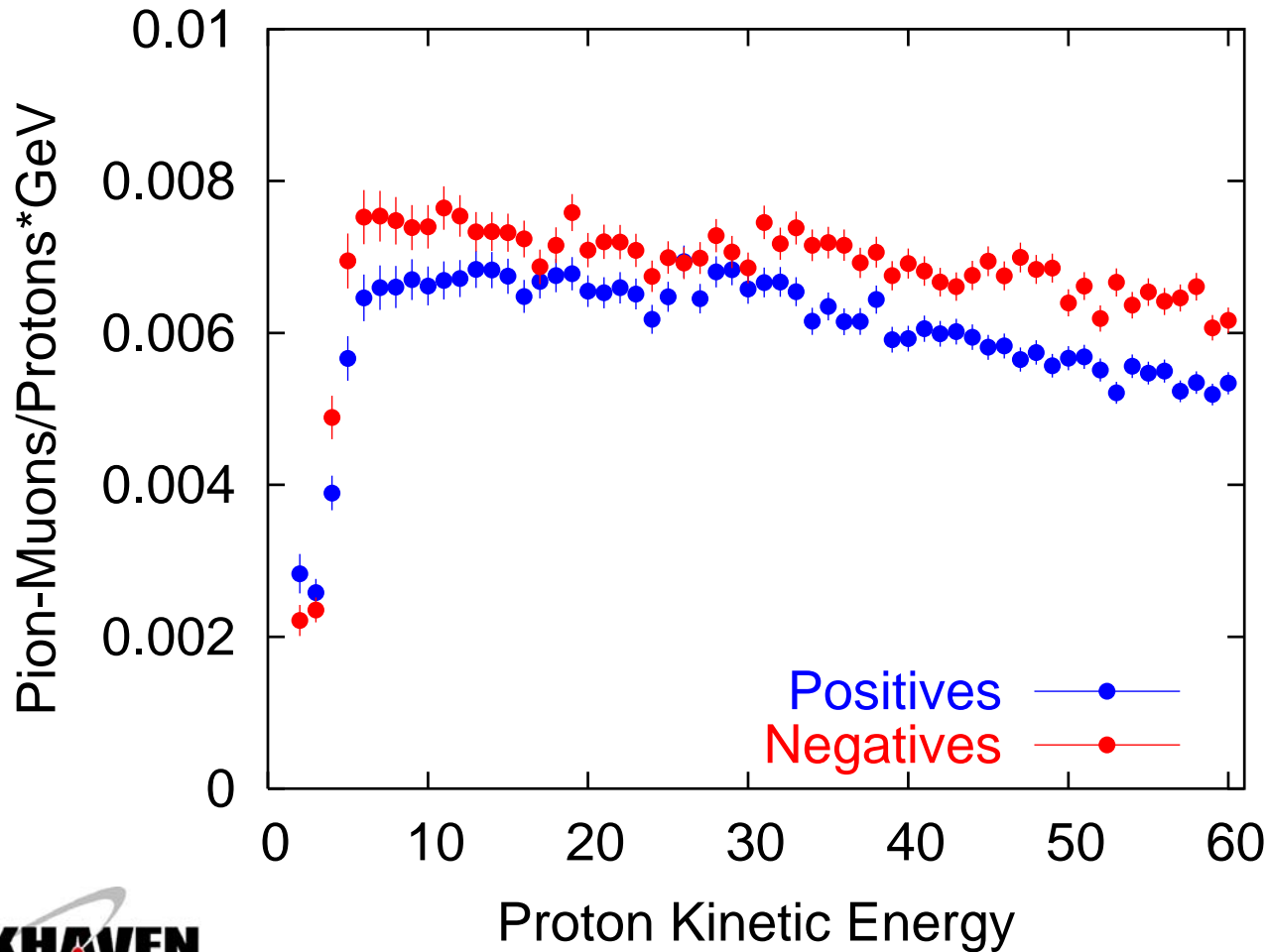

Carbon Target Parameters Search

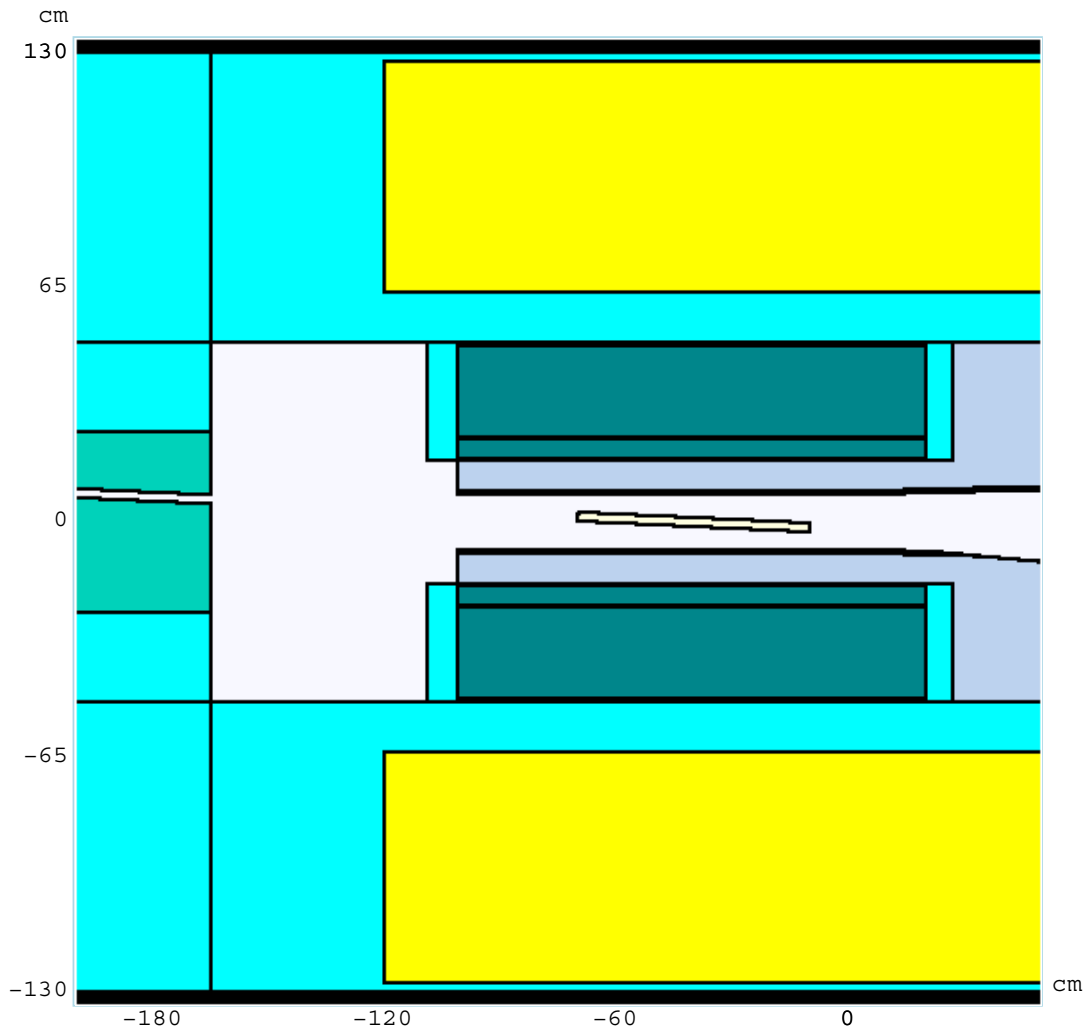

Carbon Target Optimization

MARS14

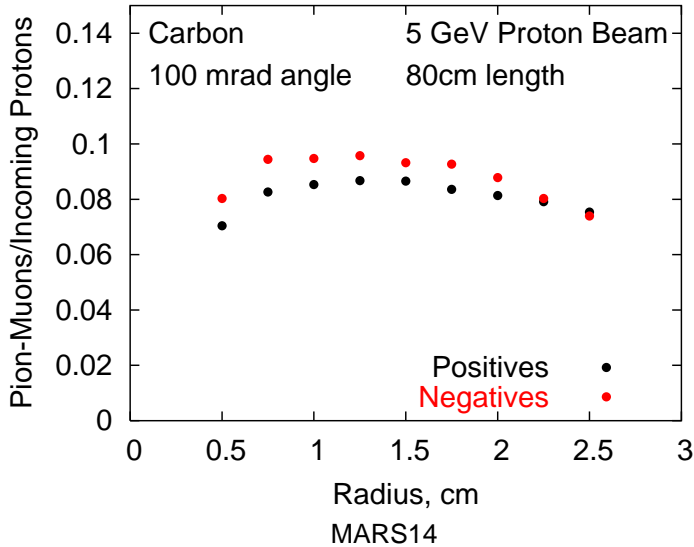

MARS14

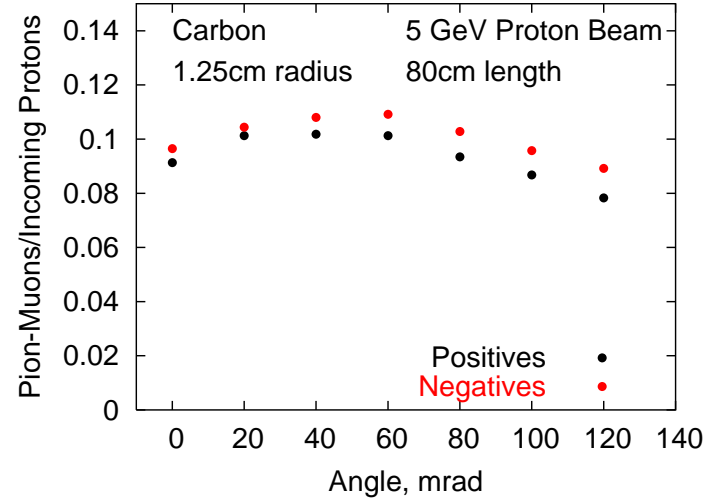

MARS14

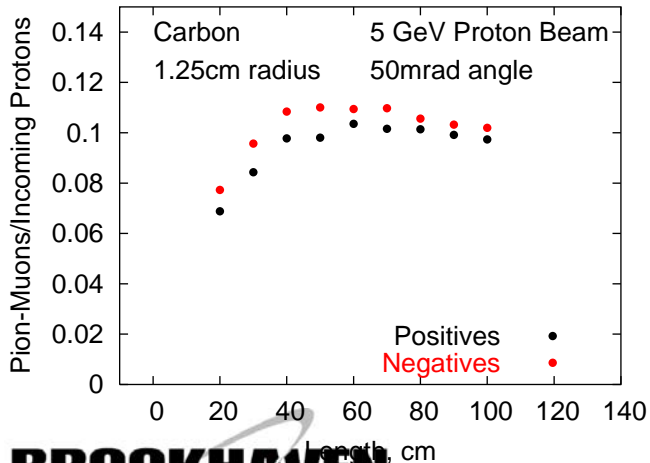

MARS14

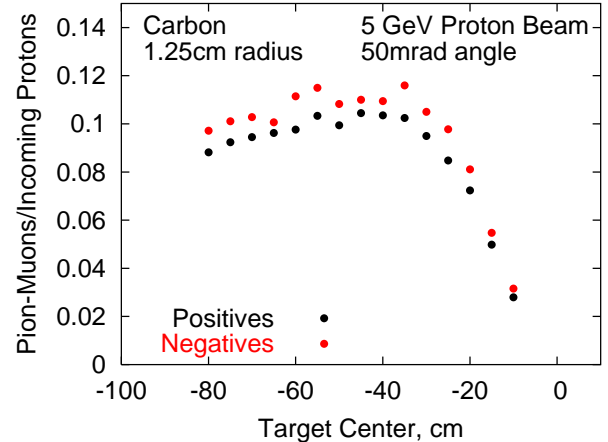

Summary of Results

**Compare Meson
production for Hg at 24
GeV and 10 GeV**

$$\frac{N^+_{10\text{GeV}}}{N^+_{24\text{GeV}}} = 1.07 \quad \frac{N^-_{10\text{GeV}}}{N^-_{24\text{GeV}}} = 1.10$$

**Compare Meson
production for C at 24 GeV
and 5 GeV**

$$\frac{N^+_{5\text{GeV}}}{N^+_{24\text{GeV}}} = 1.90 \quad \frac{N^-_{5\text{GeV}}}{N^-_{24\text{GeV}}} = 1.77$$

**Compare Meson
production for Hg at 10
GeV and C at 5 GeV**

$$\frac{N^+_{\text{Hg}-10\text{GeV}}}{N^+_{\text{C}-5\text{GeV}}} = 1.18 \quad \frac{N^-_{\text{Hg}-10\text{GeV}}}{N^-_{\text{C}-5\text{GeV}}} = 1.22$$



The Target Experiment at CERN

“R&D on the muon production target experiment at CERN will also be funded”

Presidential FY07 Budget Request to Congress

The MERIT (nTOF11) Experiment

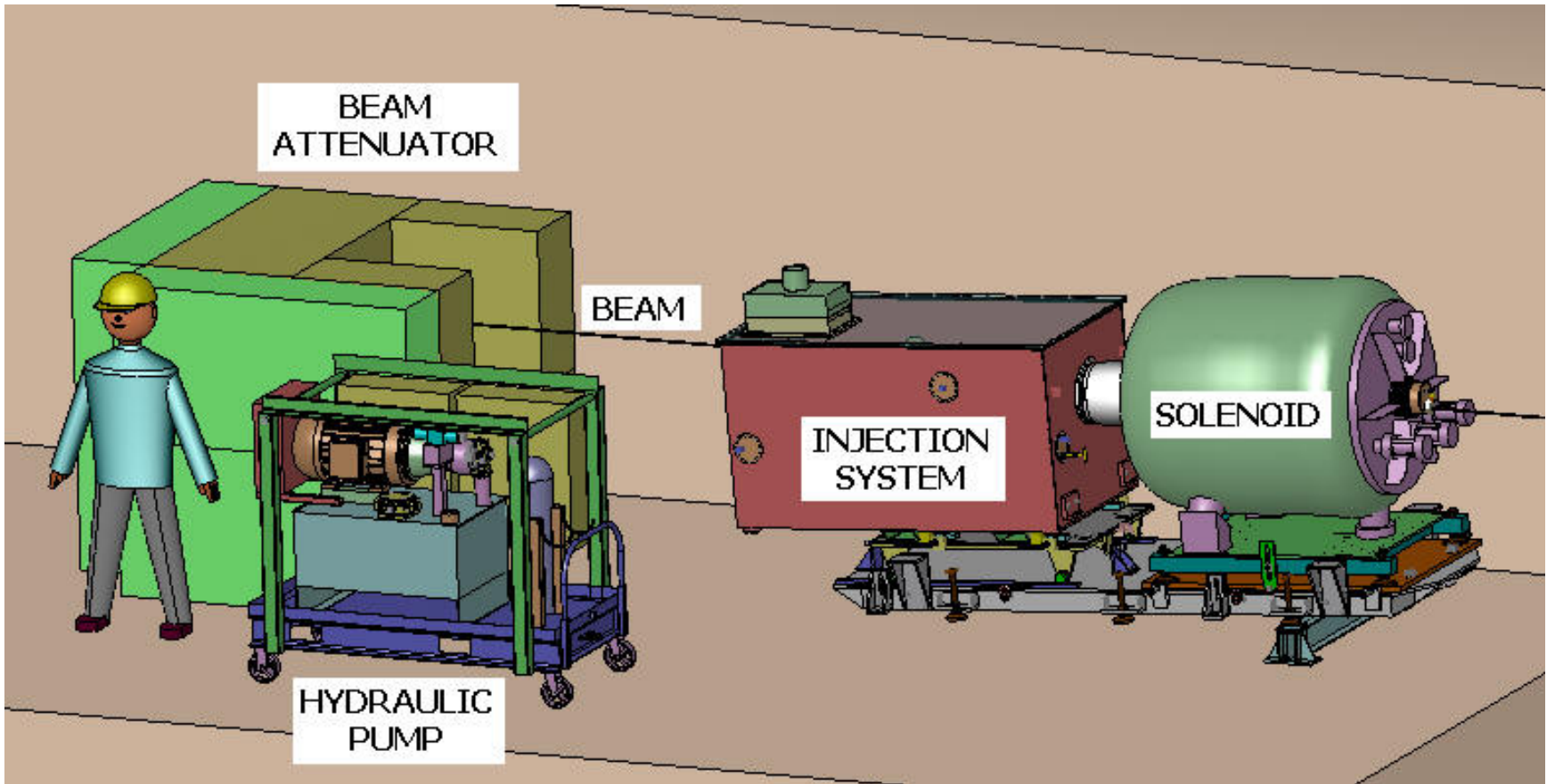

MERcury Intense Target

Target Test Site at CERN

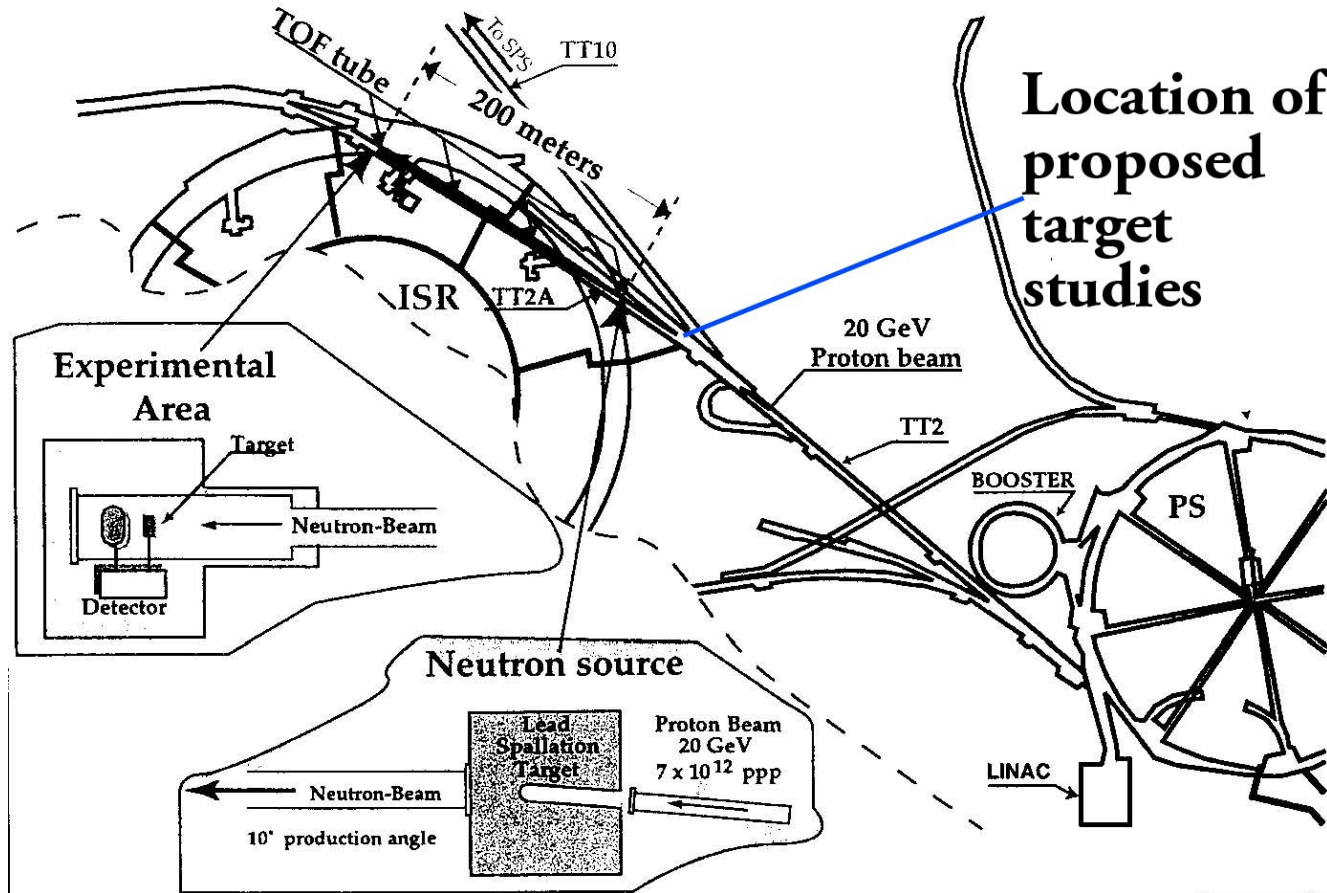

The Tunnel Complex

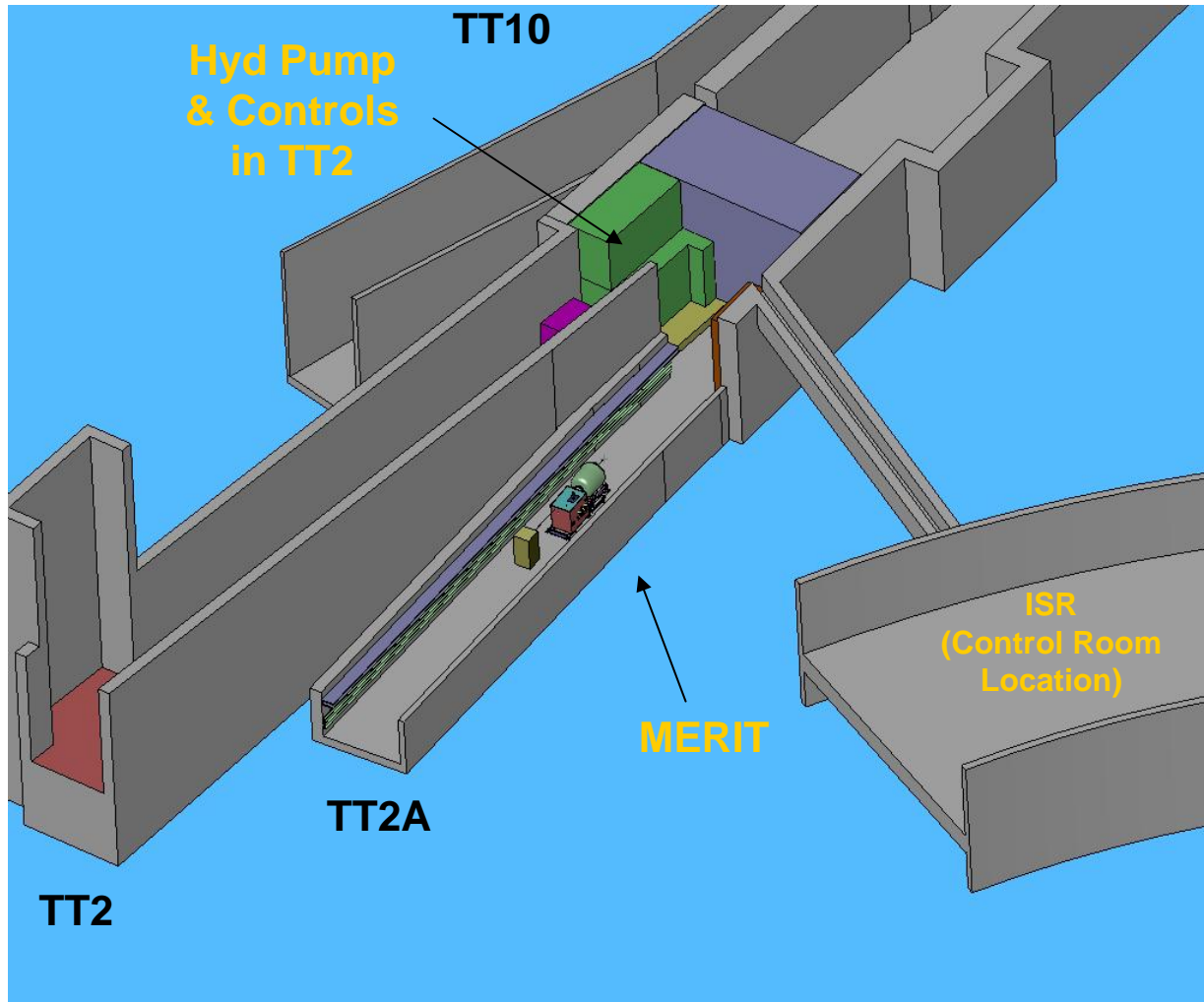



Profile of the Experiment

- 14 and 24 GeV Proton beam
- Up to 30×10^{12} Protons (TP) per $2\mu\text{s}$ spill
- Proton beam spot with $r \leq 1.5$ mm rms
- 1cm diameter Hg Jet
- Hg Jet/Proton beam off solenoid axis
 - Hg Jet 33 mrad
 - Proton beam 67 mrad
- Test 50 Hz operations
 - 20 m/s Hg Jet
 - 2 spills separated by 20 ms



PS Beam Characteristics

- PS will run in a harmonic 16 mode
- We can fill any of the 16 rf buckets with sub-bunches at our discretion.
- Each microbunch can contain up to 2.5 TP.
- Fast extraction can accommodate entire $2\mu\text{s}$ PS fill.
- Extraction at 24 GeV
- Partial/multiple extraction possible at 14 GeV
- Beam on target **April 2007**



Run plan for PS beam spills

The PS Beam Profile allows for:

- Varying beam charge intensity from 4 TP to 30 TP.
- Studying influence of solenoid field strength on beam dispersal
(vary B_0 from 0 to 15T).
- Study possible cavitation effects by varying PS spill structure (Pump/Probe)
- Study 50 Hz operation.



Key Experimental Sub-systems

15T Pulsed Solenoid

5.5 MVA Power Supply

LN₂ Cryo-system

Hg Jet Delivery System (K. McDonald)

Diagnostics (K. McDonald)

Optical

Particle Detection

CERN Infrastructure (I. Efthymiopoulos)

Simulations (R. Samulyak)

High Field Pulsed Solenoid

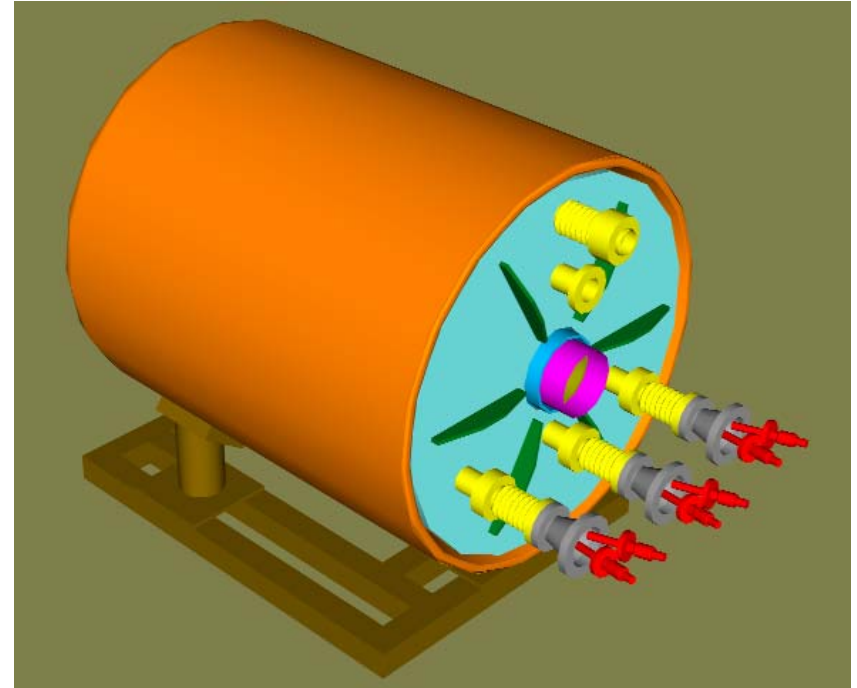
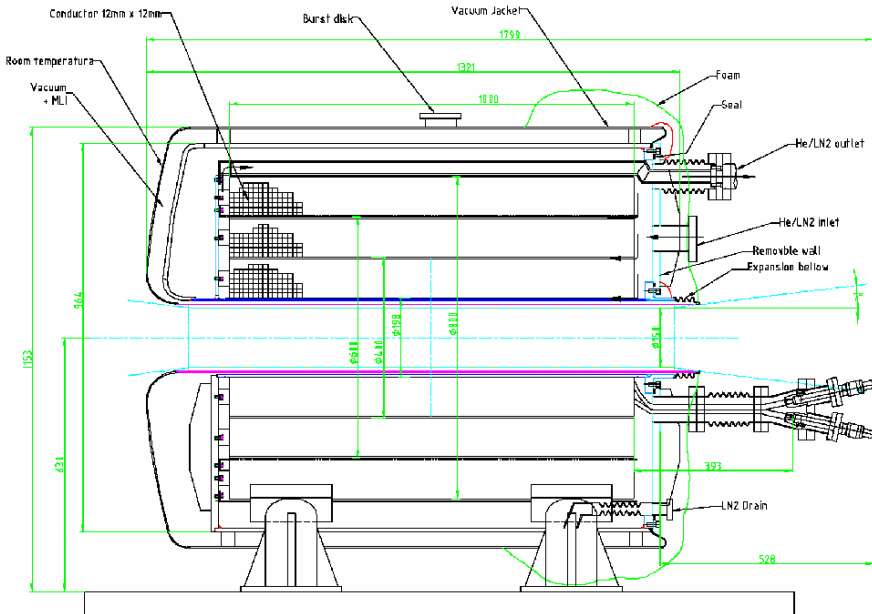

- **80° K Operation**
- **15 T with 5.5 MVA Pulsed Power**
- **15 cm warm bore**
- **1 m long beam pipe**

Peter Titus, MIT



Pulsed Solenoid Milestones

Delivery to MIT

January 06

Reception Testing

March 06

Integration Testing

September 06

Ship to CERN

December 06

Installation at CERN

January 07

The Pulsed Solenoid



CVIP December 2005

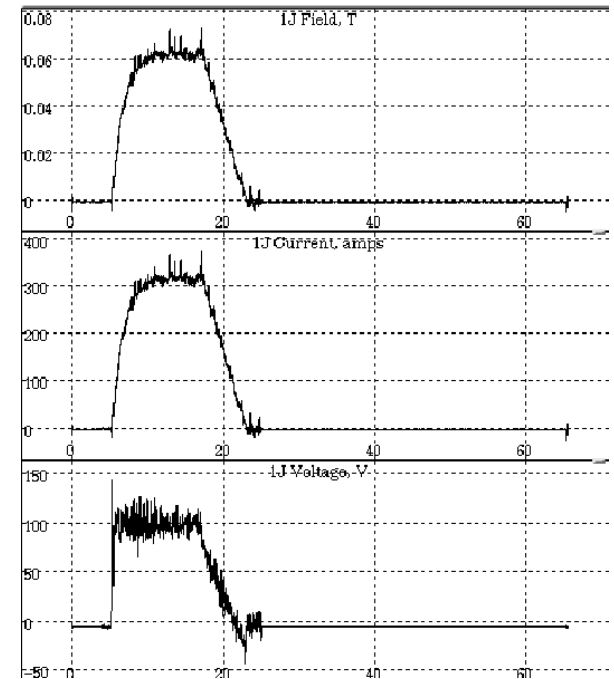

First Current: MIT
March 9, 2006



Power Supply Milestones

Site Preparations

January 06

Relocate and Install

February 06

DC Cabling

March 06

AC Cabling

October 06

Refurbish PS

October 06

Interlocks

September 06

Commissioning

October 06



Cryogenic System Milestones

TT10 Vent Installation	January 06
Cold Valve Box Fabrication	April-July 06
Control System Development	January-June 06
Surface Preparations	May 06
Transfer Line Installation	July 06
Cold Valve Box Testing	October 06
Heater System Installation	September 06
Cold Valve Box Installation	November 06
Commissioning	December 06

Cryosystem Layout

LN₂ and N₂ gas stored on the surface.

Cold valve box in the TT2 tunnel.

Exhaust gas vented into TT10 tunnel through filtration system.

~ 150 liters of LN₂ per Magnet pulse.

Magnet flushed with N₂ prior to each pulse, to minimize activation of N₂.

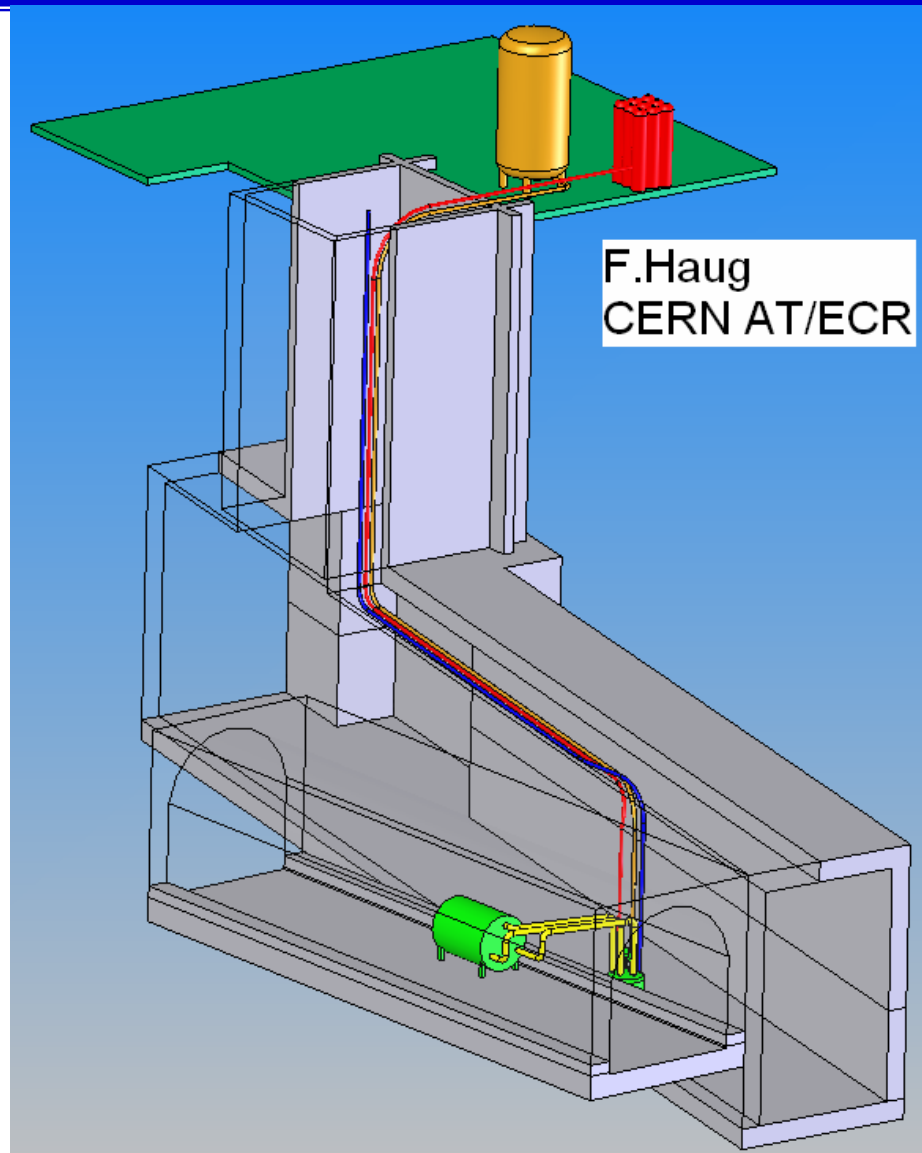

The Hg Jet System

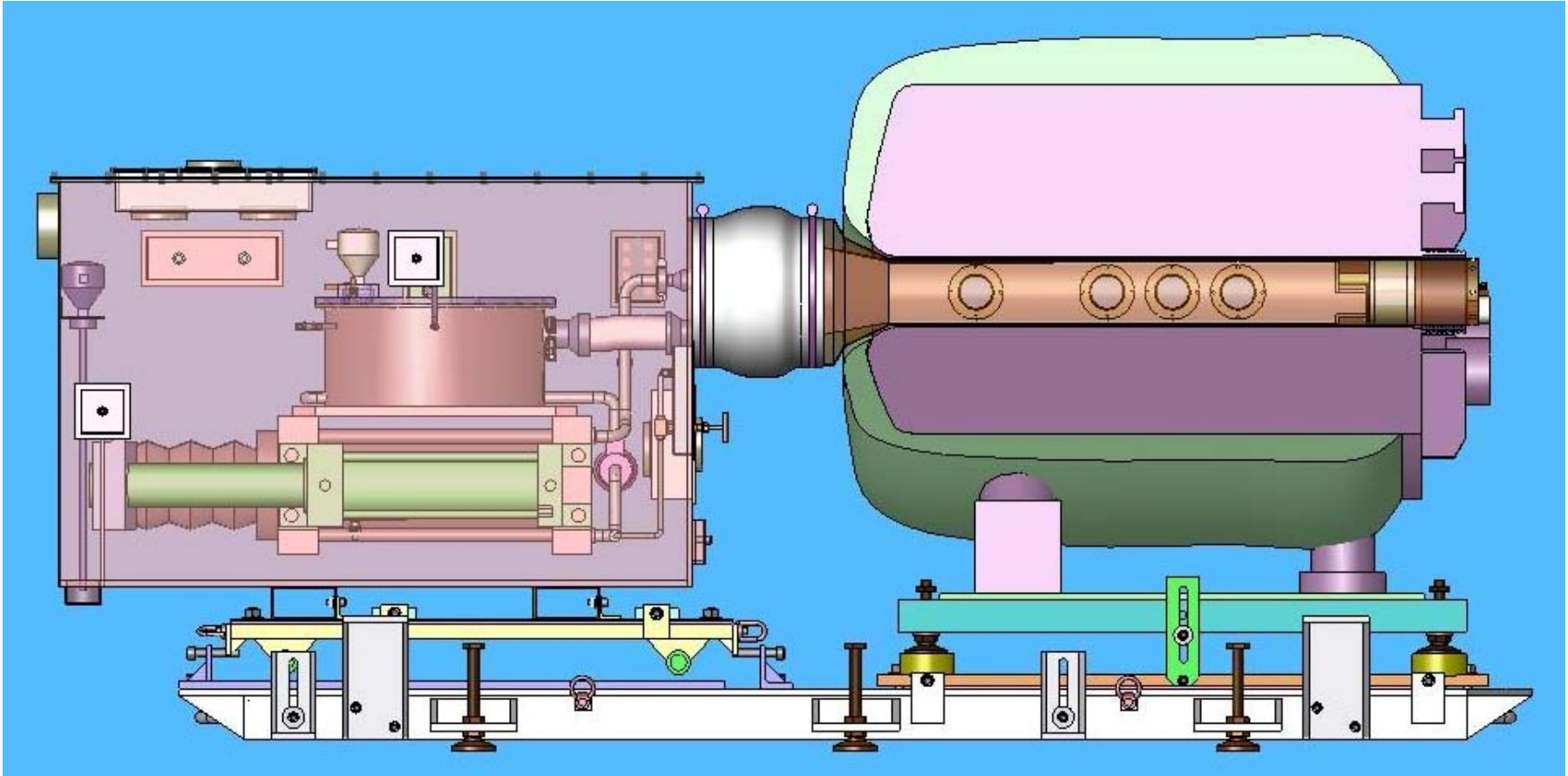

Princeton Nozzle R&D

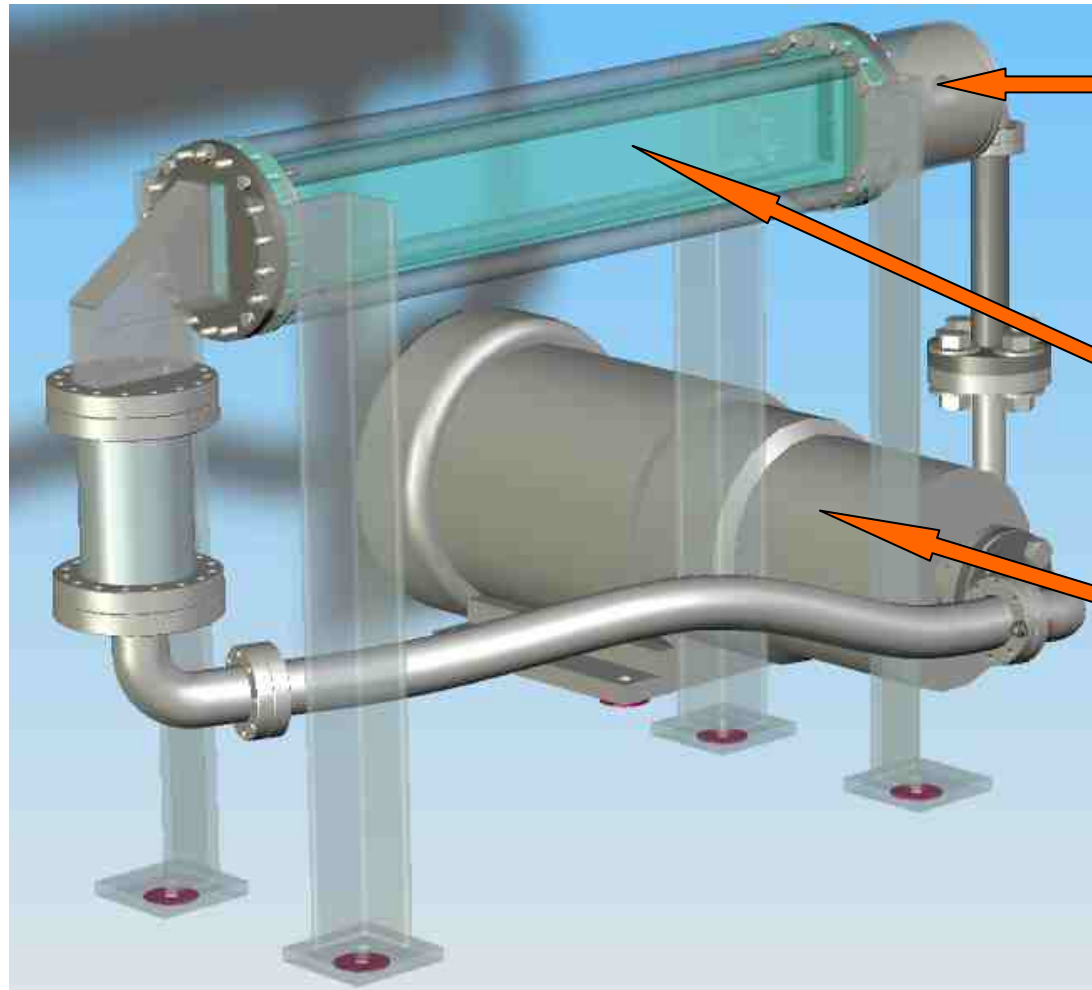

Replaceable Nozzle Head

Lexan Viewing Channel

20 HP Pump

Summary

The MERIT (nTOF11) Experiment

- Study single beam pulses with intensities up to 30TP
- Study influence of solenoid field strength on Hg jet dispersal (B_0 from 0 to 15T)
- Study 50 Hz operations scenario
- Study cavitation effects in the Hg jet by varying PS spill structure—Pump/Probe
- First beam expected April 2007
- **Confirm Neutrino Factory targetry concept**



Backup Slides



Budget and Funding Profile

	Tech. Board	MERIT Review	Spending Profile by FY		
	Sept. 21	Dec. 12	FY05	FY06	FY07
	2004	2005			
Magnet Systems					
Fabrication	0	60	60	0	0
Testing	200	200	48	112	40
Cryogenics	550	385	0	250	135
Power Supply	390	210	0	160	50
Hg Jet					
Systems integration	200	200	85	75	40
Nozzle development	50	65	25	40	0
Optics components	25	100	16	74	10
Fabrication	40	170	0	170	0
Shipping	0	20	0	14	6
Operations	218	263	19	65	179
Decommissioning	60	60	0	0	60
Simulations	150	150	40	50	60
Material R&D	75	75	30	0	45
3 Year Project Cost	1958	1958			
Spending Profile			323	1010	625
Funding Profile			693	640	625

Project Major Sub-systems

	2005 Q4	2006 Q1	2006 Q2	2006 Q3	2006 Q4	2007 Q1
Magnet						
Magnet Delivery		■				
Receiving Testing		■				
Integration Testing					■	
Shipping					■	
Installation						■
Hg Jet						
System Fabrication		■				
Nozzle Development		■				
Optical Diagnostics		■				
System Testing ORNL				■		
System Testing MIT					■	
Shipping					■	
Installation						■



CERN Infrastructure

	2005 Q4	2006 Q1	2006 Q2	2006 Q3	2006 Q4	2007 Q1
Power Supply						
Site Preparations		■				
Installation		■				
DC Cabling			■			
AC Cabling			■			
Interlocks					■	
Commissioning					■	
Cryogenics						
TT10 Vent		■				
Cold Valve Box Fab.			■	■		
System Testing CERN					■	
Surface Preparations				■		
Tunnel Installations					■	
Commissioning						■