

KL Status Report

(basically from previous presentations and MICE Status report-December 2008)

- ❑ Installation & Commissioning
- ❑ Results of first runs of data taking
- ❑ Magnetic linking (Virostek plate-TOF2-KL) and new supporting trolley in downstream PID region

KL Test at Roma III and Installation at RAL

At the beginning of 2008 the detector has been tested and calibrated at Roma III laboratory and it has been sent to RAL in June for the installation in a provisional position of the MICE Hall in preparation.

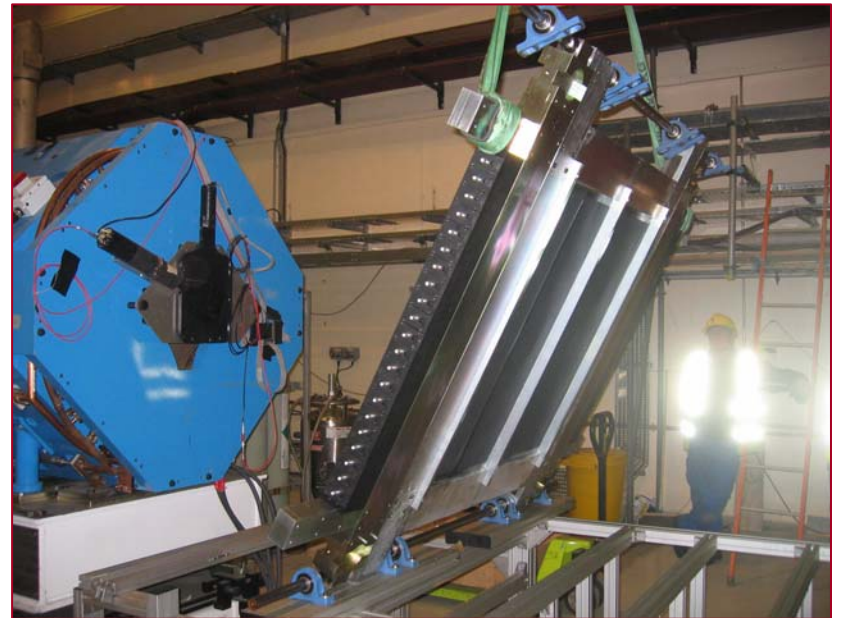

The pictures show KL detector under test at Roma III and under installation in the MICE Hall at RAL

KL detector at RAL

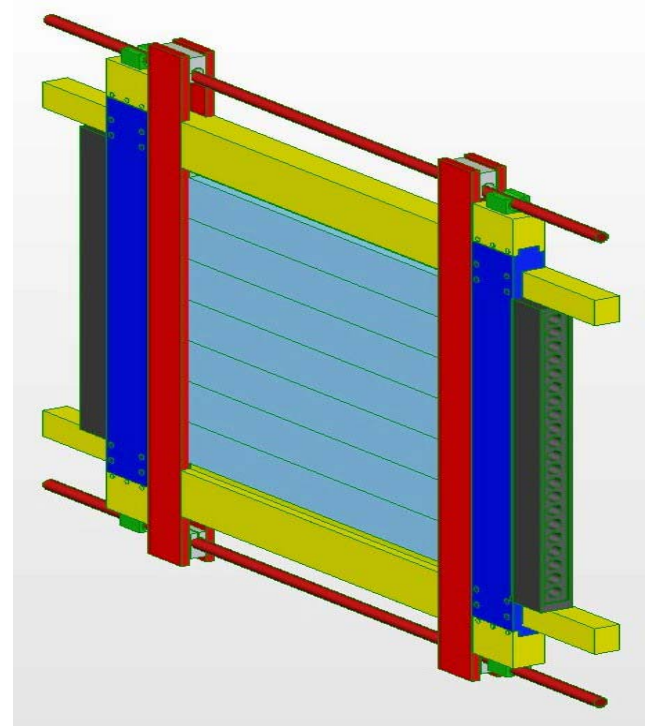
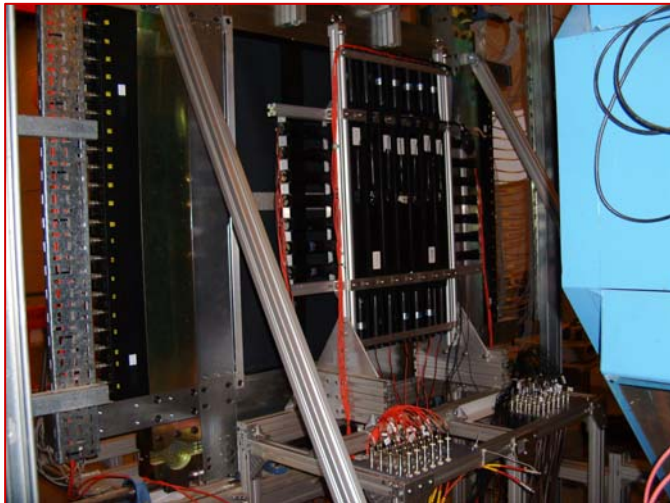

**The first part of EMC,
(the Electron-Muon-Calorimeter)
formed by the electron identifier
KL (KLOE-Like lead-scintillating
fiber calorimeter) is now operating
"in symbiosis" with TOF1**

KL commissioning (RC)

The installation in the provisional position, upstream with respect to the final one, and the commissioning work by means of cosmic rays has been completed at the beginning of July

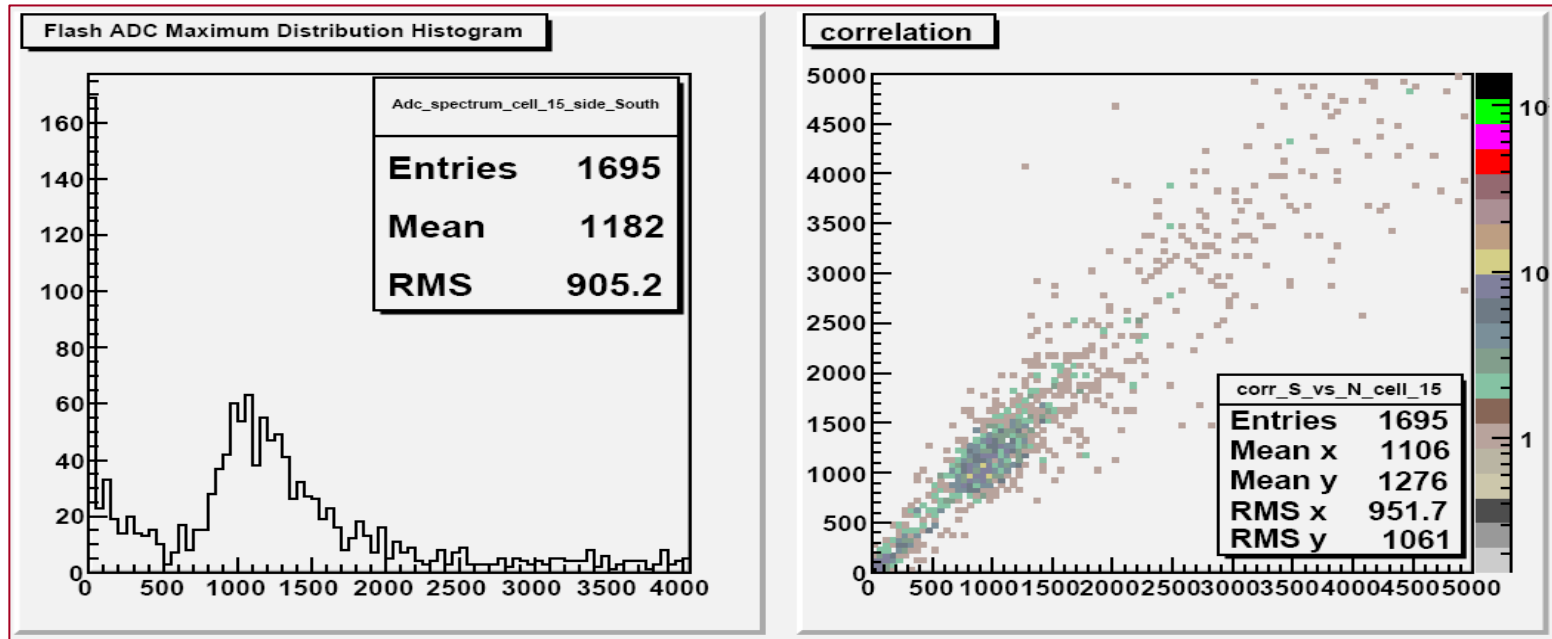

MIP distribution and the correlation left-right of the PMT's signals.
See as reference for details at <https://micelog.dl.ac.uk/MICE+Log/151>

KL commissioning (π^+)

At the beginning of November the KL detector has been exposed for the first time to the pion (300 MeV)

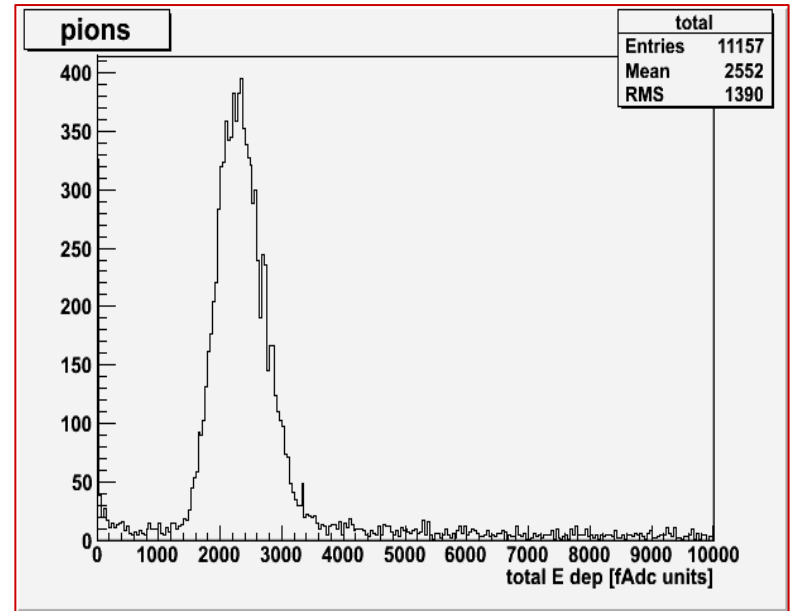
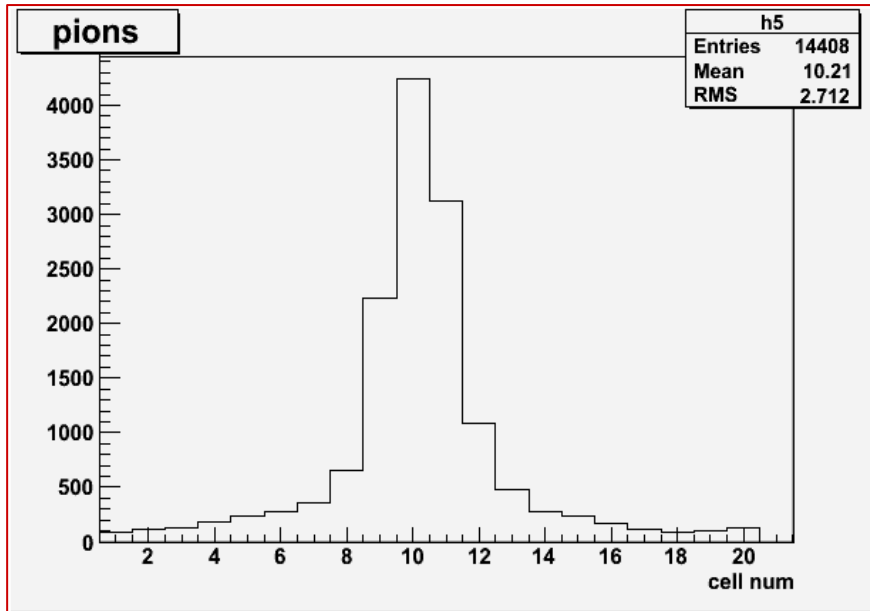

Results of FADCs analysis show the beam's profile and the energy reconstruction in agreement with the expected resolution

KL commissioning (e^+)

Last November the KL detector has been exposed also to the positrons (100 MeV)

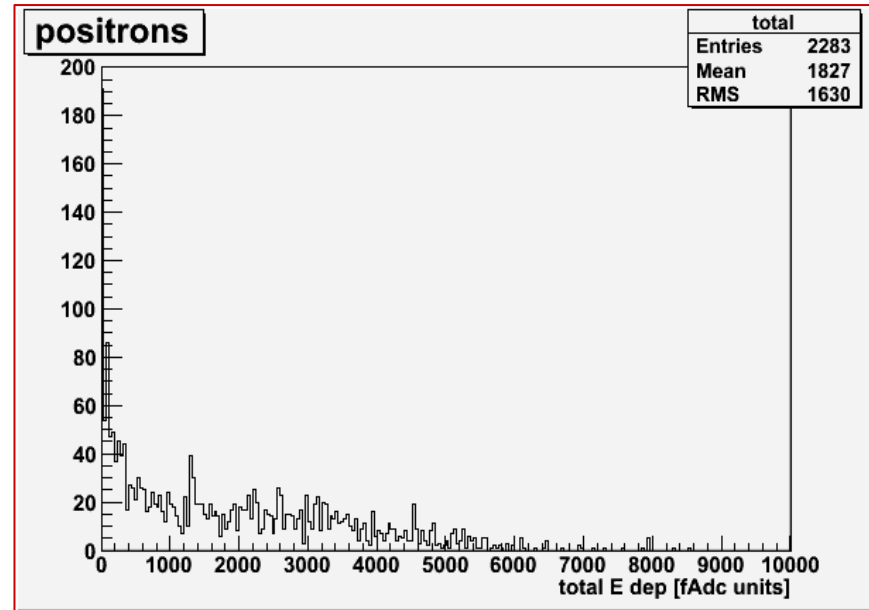
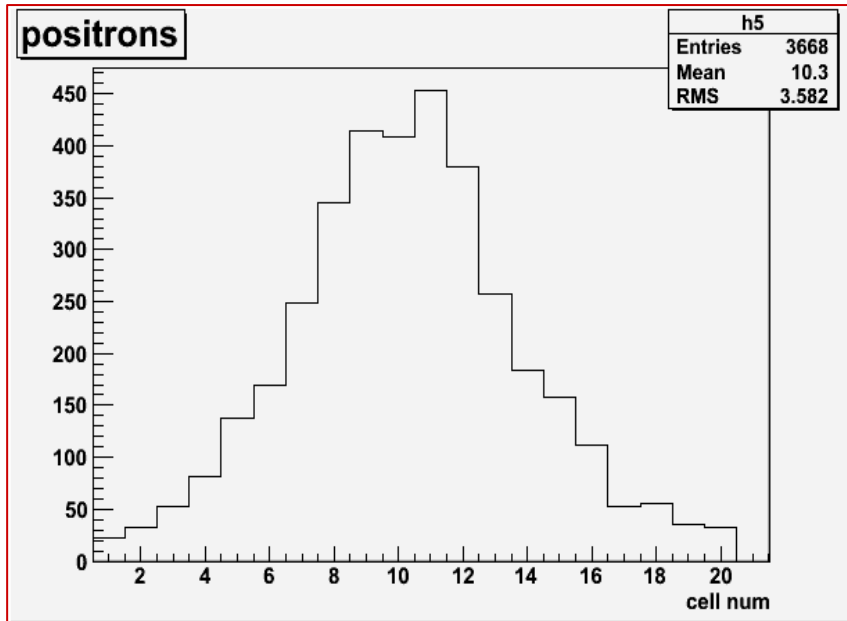

Results of FADCs analysis show the beam's profile (broader than π^+) and the energy reconstruction indicating that the positron beam is significantly degraded before reaching KL

TOF2 shielding frame

Shielding frame of TOF2 to be built
mechanically joinable both
with KL's frame
and
Virostek plate
to offer
the best magnetic contact
and
the best resistance to magnetic forces

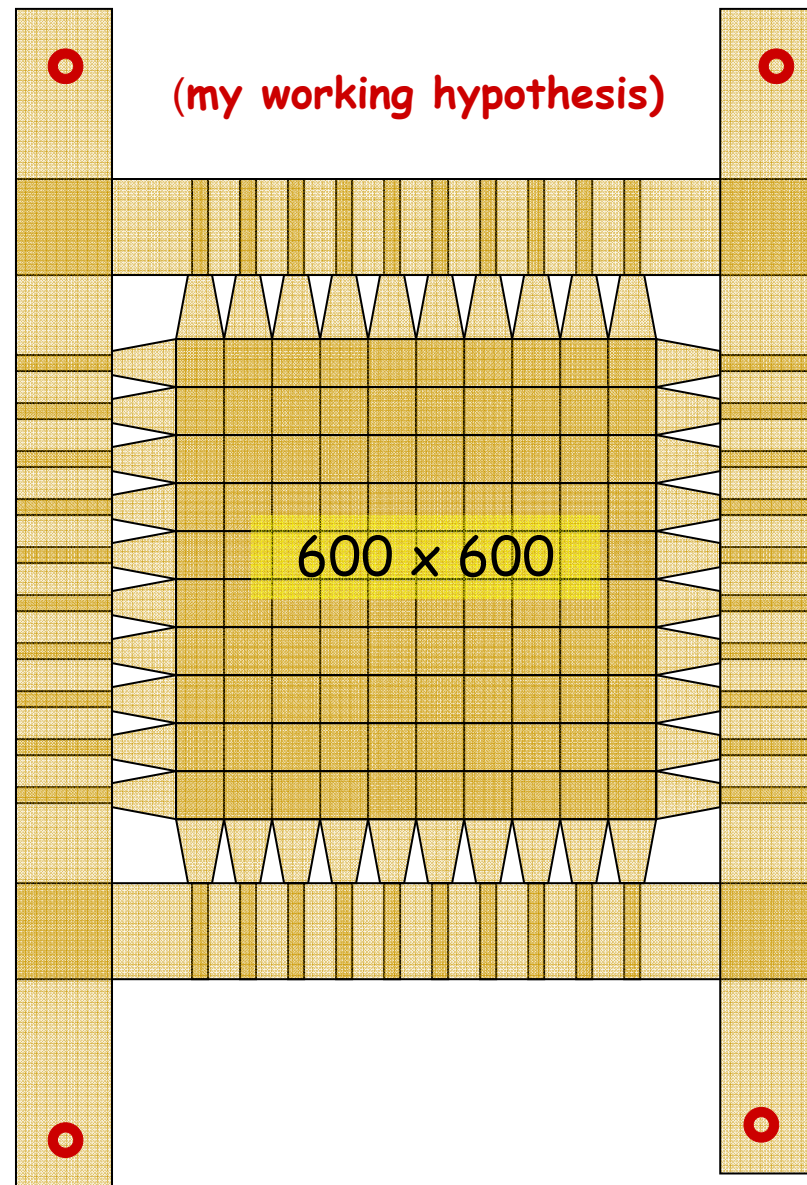

Linking of TOF2 & KL shielding frames

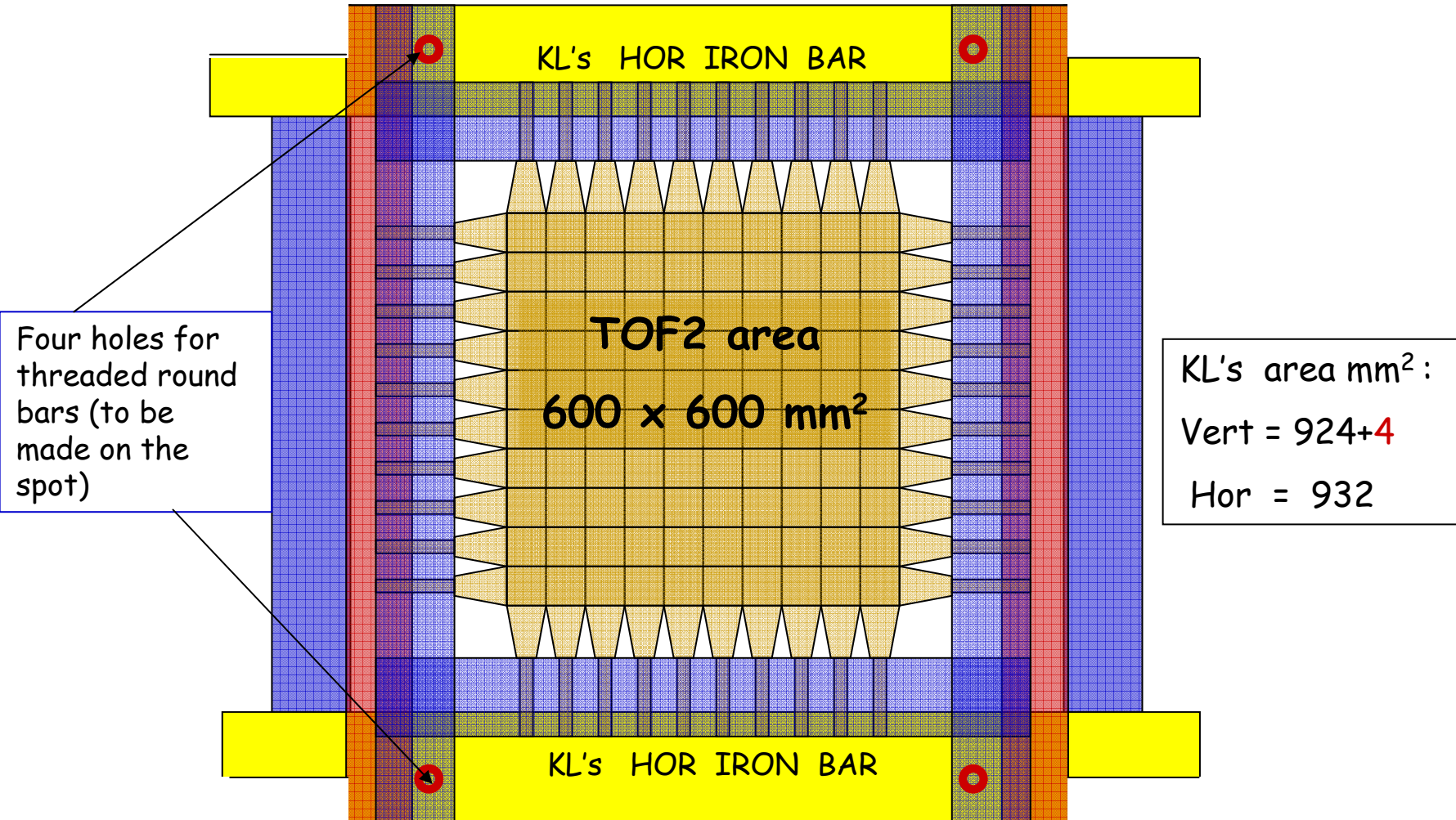

Installation of TOF2 & KL & Virostek plate in the final downstream beam area

to be checked:

- Virostek plate linking (Wing)
- Brackets constraints (see drawing)
- Platform slot for trolley (Andy)

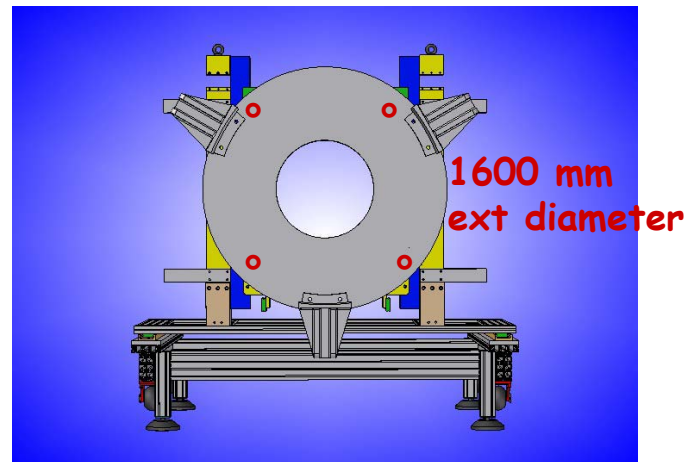

(lateral anchorages to the floor not shown)

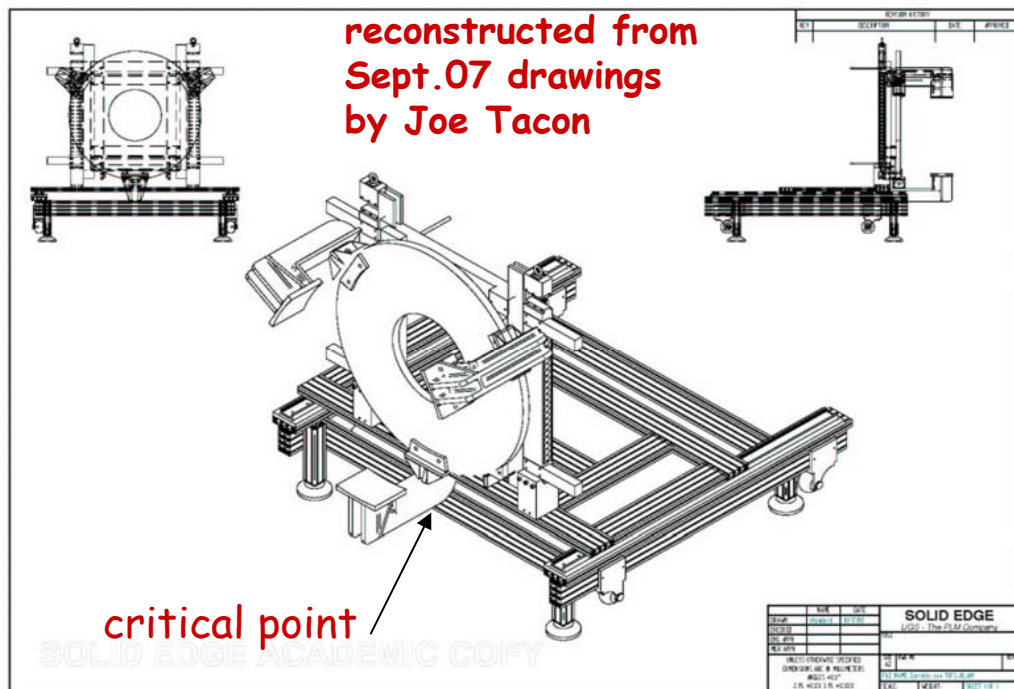
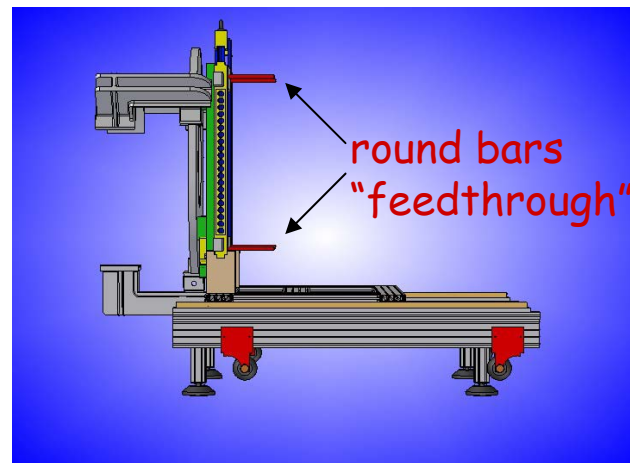

Assembling sequence of Downstream PID Detectors

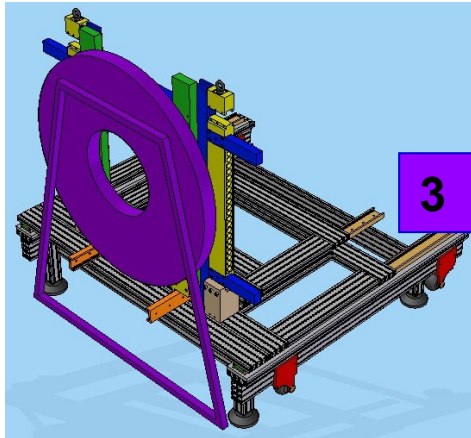
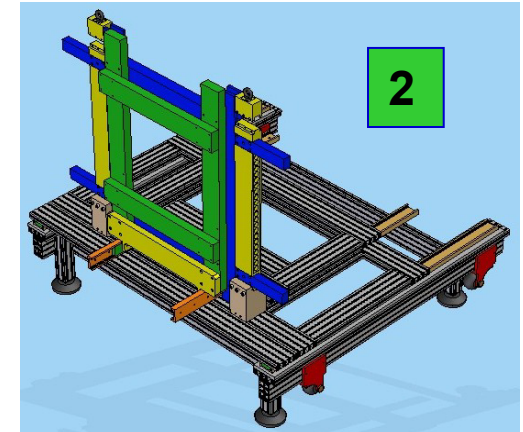
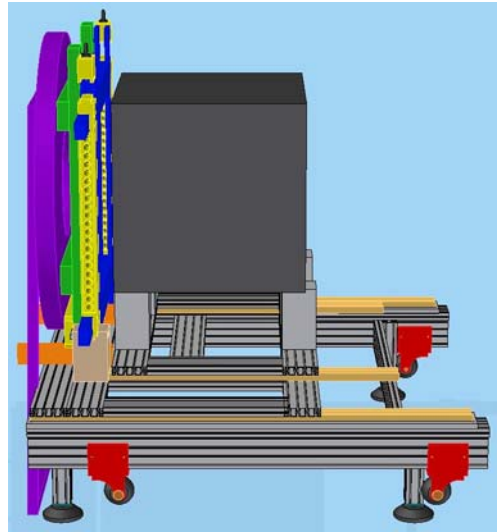
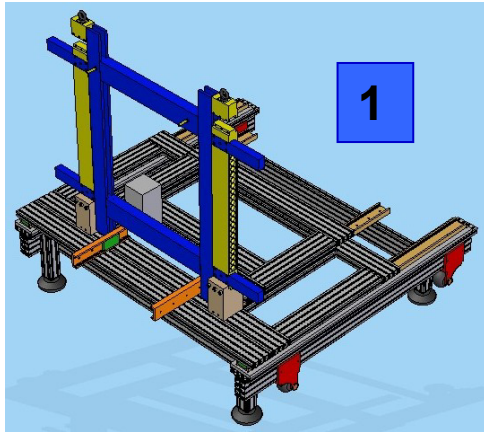

MICE-NOTE-GEN-151

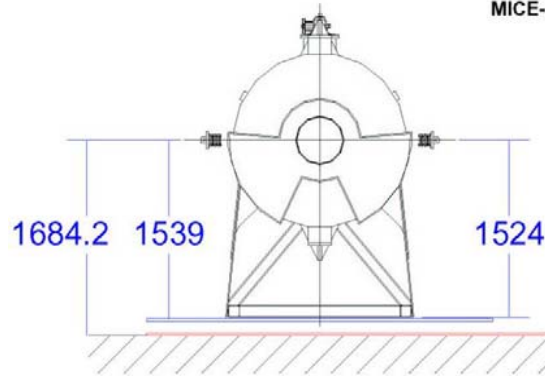

BASIC HEIGHT DIMENSIONS

NOTE THE GAP BETWEEN 1524 mm AND 1539 mm DIMENSIONS !

THIS IS TO ALLOW THE USE OF MODULE LEVELLING SHIMS

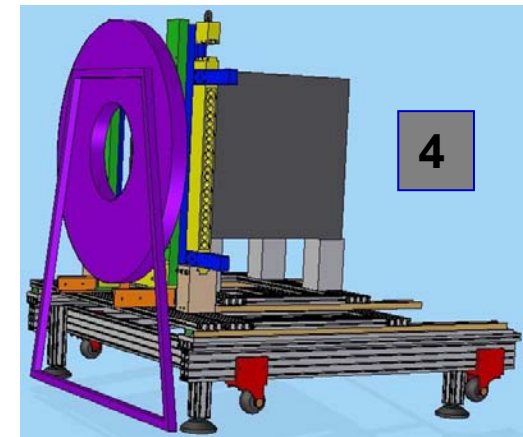

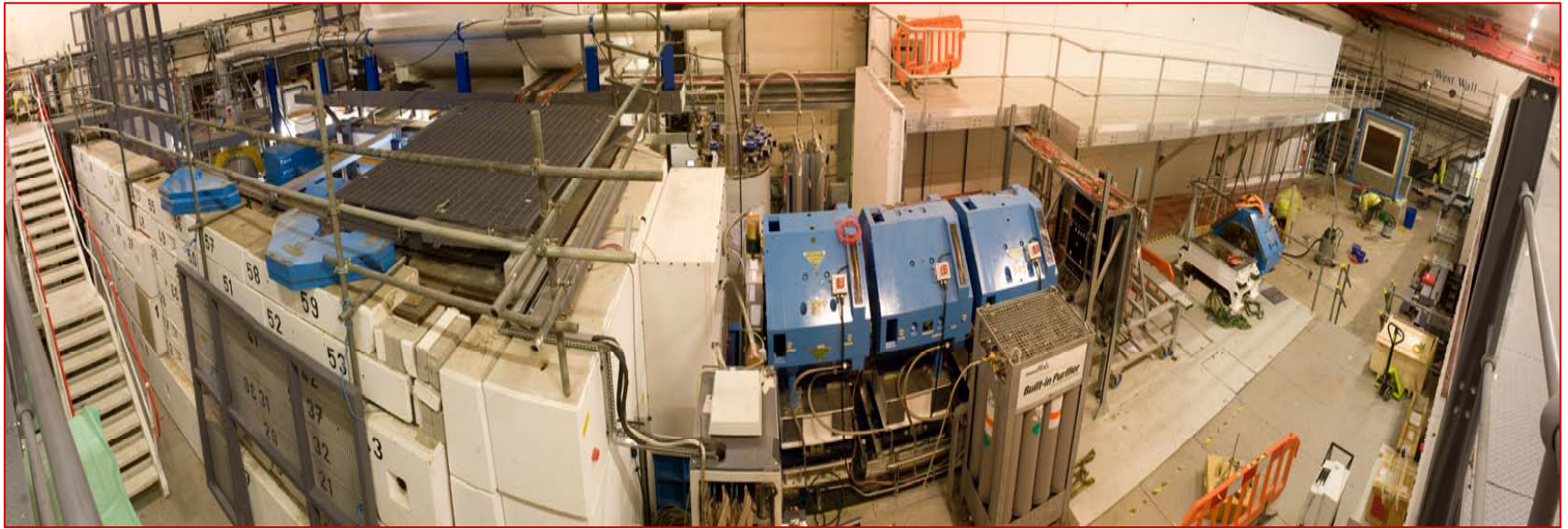

- The KL detector is now in operation with the final magnetic shielding of photomultipliers fully built by the INFN mechanical workshop at Roma III; it stands on a provisional trolley, realized by Roma III team, able to support and move KL itself and possibly a full scale prototype of SW, the Muon Ranger which is the second part of the EMC.
- Next construction duty for us is the completion of the design and the realization of the final trolley, able to support and move also TOF2 (the third station of the time of flight system) and the SW detector.